

Topic 7 Orthographic Projections

- **Ortho** means ⊥ (right angle) at 90° .
- **Graphic** means written down (drawn)
- **Projection** means to throw forward [To through straight forward & write down]

(1) What do you mean by orthographic projections.

- **Definition** : The observer is imagined at infinite distance from plane of projection, the rays(or projectors) are parallel to each other and perpendicular as to the plane of projection. Since projectors are ⊥ as to the plane of projection. The view is called orthographic view and projection method is called orthographic projection.
- IT is a two dimensional object (i.e From 3D to 2D)

(2) Draw symbols for 1st angle projection method and 3rd angle projection method.

- **Projection Symbol :**

- It is mandatory that the system of projection used, namely first angle(or) third angle, should be symbolically specified in the title block .
- These symbols are the two views of a frustum of a cone whose axis is horizontal .
- In first angle projection, the top view comes below the front view; the left side view to the right and the right side view to the left of the front view.

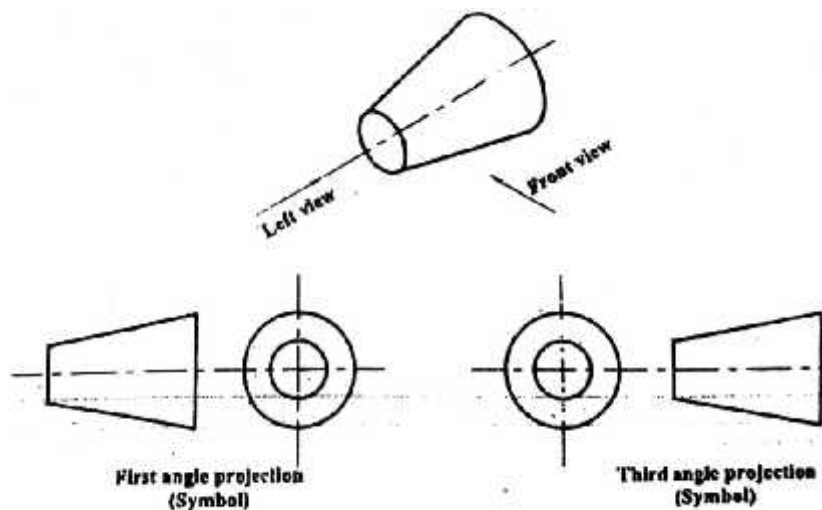

-But in the third angle projection, the top view comes above the front view, the left side view to left and the right side view to the right of the front view.

-The symbol for first angle and third angle projection are shown in fig ..

(3) Differentiate between First angle projection method and Third angle projection method.

<u>1st angle Projection</u>	<u>3rd angle projection</u>
(1) Object is kept in first Quadrant	(1) Object is kept in third Quadrant
(2) Object lies between observer and plane of Projection. (So plane is assumed non-transparent)	(2) Plane of projection lies between observer and object. (So plane is assumed to be transparent)
(3)Front view is drawn above XY Line and Top view below XY line.	(3) Front view is drawn below XY Line and Top View above XY line.
(4) Left view is drawn on right side of front view and -Right side view is drawn on left side of front view.	(4)Left hand view is drawn on left side of front view and -Right side view is drawn on right side of front view
(5) Followed (or Used) in India ,European countries.	(5)Follow (or Used) in U.S.A and Canada.

Symbol of 1st Angle Symbol of 3rd Angle

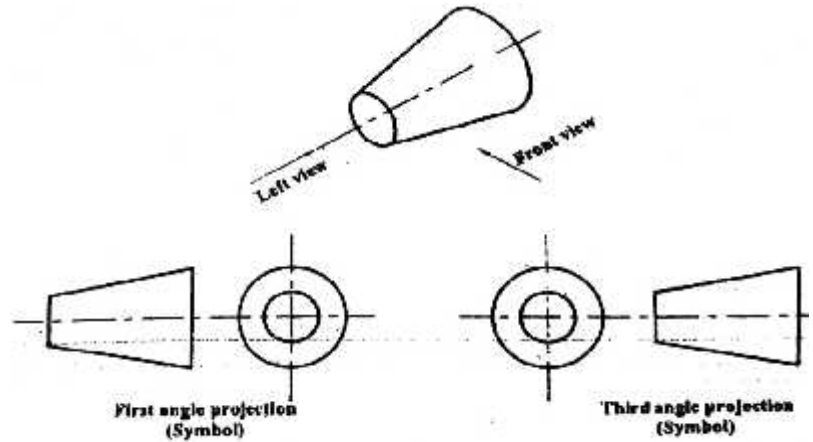

(4) Why we can not use second angle and Fourth angle projection method?

- In second Quadrant , projections of object are drawn above XY Line.
- If object is projected in fourth quadrant , Its F.V. And T.V are drawn below XY.
- So in both quadrants F.V and T.V. are Overlapping or lines of views coincide each other.
- It will become very difficult to understand views.
- So we can not use second and Fourth Quadrant projection method.